

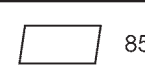













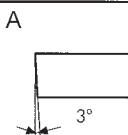
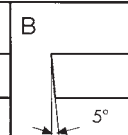

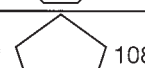



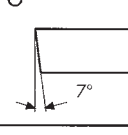
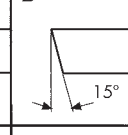

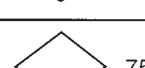

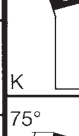

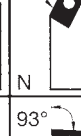
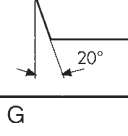
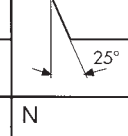
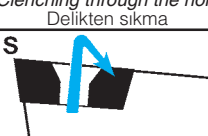

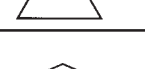

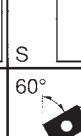

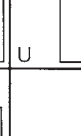
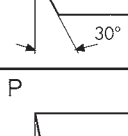
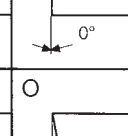
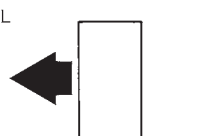
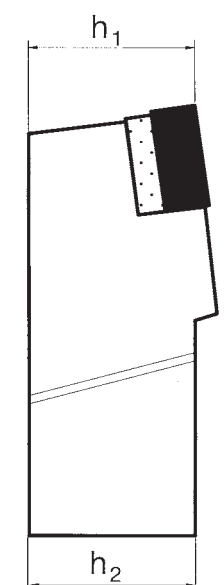
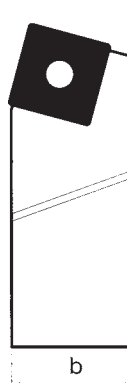
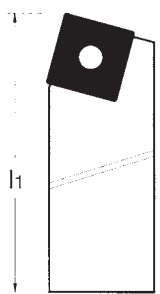
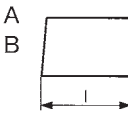
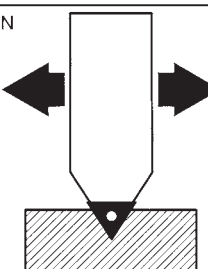
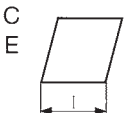
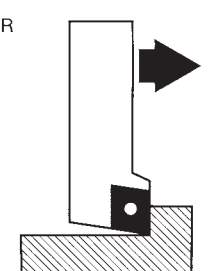
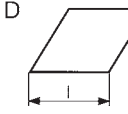
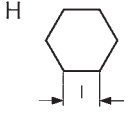

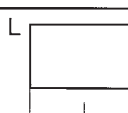
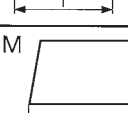
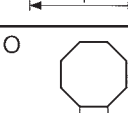
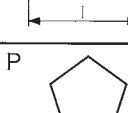
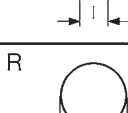
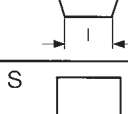
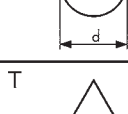
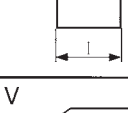
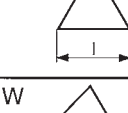
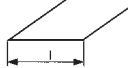

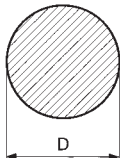
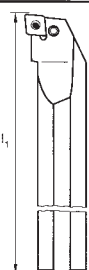
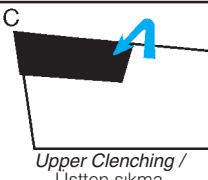
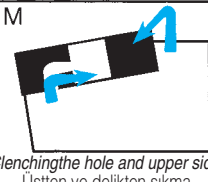
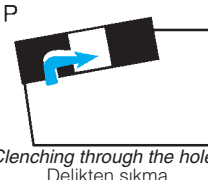
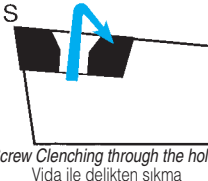

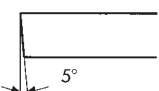
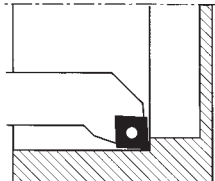
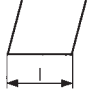

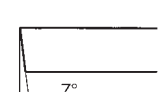
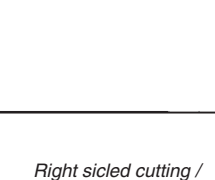



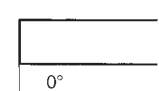

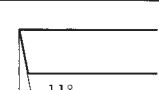

ISO Coding For External Turning Tools Dış Tornalama Takımları İçin ISO Kodlaması

P 1 Clenching type Sıkma tipi	S 2 Insert type Uç tipi		S 3 Approaching angle Yanaşma açısı				N 4 Free insert angle Uç serbest açısı	
C  Upper clenching Üstten sıkma	A  85°	M  86°	90° 	75° 	90° 	45° 	A  3°	B  5°
M  Clenching through the hold and upper side Üstten ve delikten sıkma	B  82°	O  135°	60° 	90° 	90° 	93° 	C  7°	D  15°
P  Clenching through the hole Delikten sıkma	C  80°	P  108°	E 	F 	G 	N 	E  20°	F  25°
S  Screw clenching through the hole Vida ile delikten sıkma	D  55°	R  --	K 	L 	M 	U 	G  30°	N  0°
R 5 Cutting direction Kesme yönü	25 6 Cutting edge height Kesme kenar yüksekliği		25 7 Shaft length Şaft genişliği		M 8 Shaft length Şaft boyu		12 8 Cutting edge length Kesici kenar uzunluğu	
L 							A 	
N 							C 	
R 	Cutting height (h1) is equal to shaft height (h2) in mechanical clenching tools except cartridges and internal length milling tools. Kartuşlar ve iç tornalama takımları dışında ve genel olarak mekanik sıkmalı takımlarda (h1) kesme yüksekliği, (h2) şaft yüksekliğine eşittir.						D 	
							H 	
							K 	
							L 	
							M 	
							O 	
							P 	
							R 	
							S 	
							T 	
							V 	
							W 	
							X 	
							Y 	

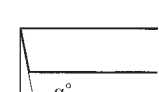
ISO Coding For Internal Turning Tools İç Tornalama Takımları İçin ISO Kodlaması

S 1			32 2	T 3	P 4																																														
Toolholder material / Takım Tutucu malzemesi			Shaft Diameter / Şaft çapı	Tool length / Takım boyu	Clenching System / Sıkma sistemi																																														
Display Character / Gösterim Harfi	Toolholder material Character / Takım Tutucu malzemesi	Construction Specifications / Konstrüksiyon Özellikleri	 08 10 12 16 20 25 32 40 50	 <table border="1"> <thead> <tr> <th></th> <th>l_1, mm</th> </tr> </thead> <tbody> <tr><td>A</td><td>32</td></tr> <tr><td>B</td><td>40</td></tr> <tr><td>C</td><td>50</td></tr> <tr><td>D</td><td>60</td></tr> <tr><td>E</td><td>70</td></tr> <tr><td>F</td><td>80</td></tr> <tr><td>G</td><td>90</td></tr> <tr><td>H</td><td>100</td></tr> <tr><td>J</td><td>110</td></tr> <tr><td>K</td><td>125</td></tr> <tr><td>M</td><td>150</td></tr> <tr><td>N</td><td>160</td></tr> <tr><td>P</td><td>170</td></tr> <tr><td>Q</td><td>180</td></tr> <tr><td>R</td><td>200</td></tr> <tr><td>S</td><td>250</td></tr> <tr><td>T</td><td>300</td></tr> <tr><td>U</td><td>350</td></tr> <tr><td>V</td><td>400</td></tr> <tr><td>W</td><td>450</td></tr> <tr><td>X</td><td>Other sizes / Diğer boyalar</td></tr> <tr><td>Y</td><td>500</td></tr> </tbody> </table>		l_1 , mm	A	32	B	40	C	50	D	60	E	70	F	80	G	90	H	100	J	110	K	125	M	150	N	160	P	170	Q	180	R	200	S	250	T	300	U	350	V	400	W	450	X	Other sizes / Diğer boyalar	Y	500	 Upper Clenching / Üstten sıkma  Clenching the hole and upper side / Üstten ve delikten sıkma  Clenching through the hole / Delikten sıkma  Screw Clenching through the hole / Vida ile delikten sıkma
	l_1 , mm																																																		
A	32																																																		
B	40																																																		
C	50																																																		
D	60																																																		
E	70																																																		
F	80																																																		
G	90																																																		
H	100																																																		
J	110																																																		
K	125																																																		
M	150																																																		
N	160																																																		
P	170																																																		
Q	180																																																		
R	200																																																		
S	250																																																		
T	300																																																		
U	350																																																		
V	400																																																		
W	450																																																		
X	Other sizes / Diğer boyalar																																																		
Y	500																																																		
	Complete stainless steel body / Yekpare çelik gövde	Standart / Standart																																																	
		Cooling water canal / Soğutma suyu kanalı																																																	
		With anti vibration / Vibrasyon gidericili																																																	
		Cooling water canal / Soğutma suyu kanalı																																																	
	Steel cap and hard metal body / Çelik başlık ve sert metal gövde	Standart / Standart																																																	
		Cooling water canal / Soğutma suyu kanalı																																																	
		With anti vibration / Vibrasyon gidericili																																																	
		With cooling water canal and anti vibration / Soğutma suyu kanalı ve vibrasyon gidericili																																																	
		Standart / Standart																																																	
	Heavy metal *) / Ağır metal *)	Cooling water canal / Soğutma suyu kanalı																																																	
*) Solid alloy has the effect to increase anti-vibration / *) Sinterlenmiş alaşımlar, vibrasyonun giderilmesinde yükseltici etki yaparlar. Örneğin wolfram-bakır gibi.																																																			
C 5	L 6	N 7	R 8	12 9																																															
Pin type / Uç tipi	Approaching angle / Yanaşma açısı	Pin free angle / Uç serbest açısı	Cutting Direction / Kesme yönü	Cutting edge length / Kesici kenar uzunluğu																																															
C  80°	F  90°	B  5°	 Lift siled cutting / Sol yönlü kesme	C E 																																															
D  55°	K  75°	C  7°		 Right siled cutting / Sağ yönlü kesme	D 																																														
R  -	L  95°	N  0°			R 																																														
S  90°	S  45°	P  11°			S 																																														
T  60°	U  93°	O  α°			T 																																														
V  35°	Q  107°	Special free angle / Özel olarak verilecek serbest açı			V 																																														

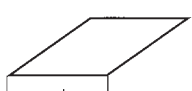

İçindekiler / Index

Delik Torna Katerleri / Internal Toolholders

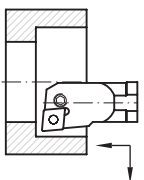
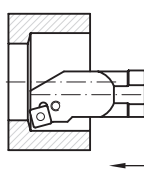
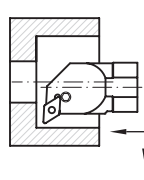
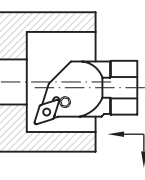
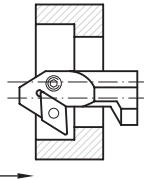
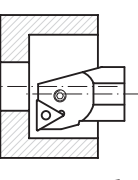
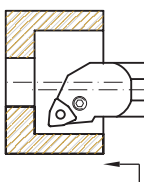
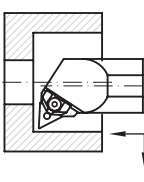
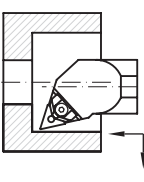
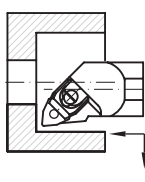
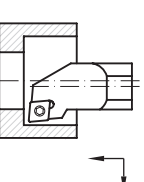
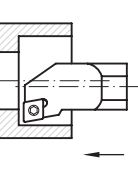
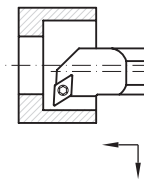
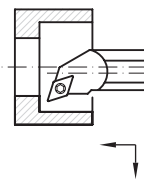
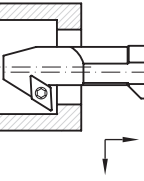
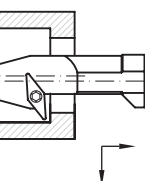
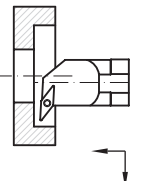
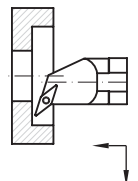
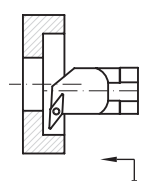
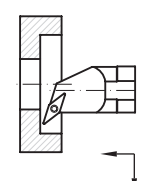
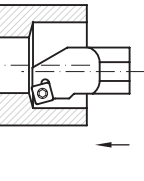
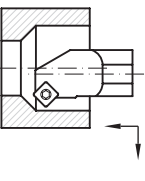
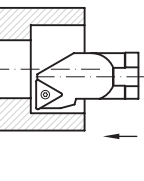
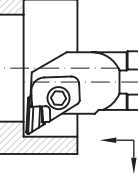
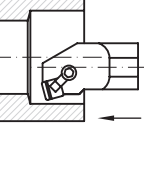
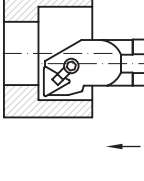
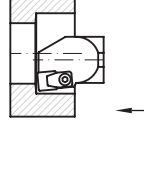
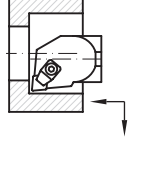
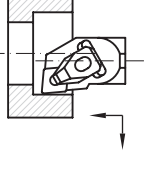
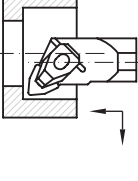
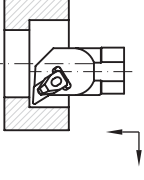
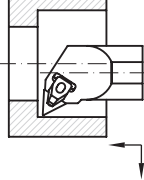
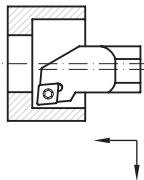
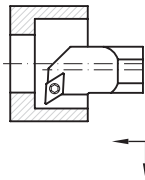



Takım Tipi (Tool Types)	PCLN	PSKN	PDUN	PDQN	PDXN	PTFN
Yanaşma Açısı (Touching Angle)	95°	75°	93°	107.5°	93°	90°
Kesme Yönü Cutting Direction						
Sayfa (Page)	48	48	49	49	49	50
Takım Tipi (Tool Types)	PWLN	MTUN	MTQN	MWLN	SCLC	SCFC
Yanaşma Açısı (Touching Angle)	95°	93°	107.5°	95°	95°	90°
Kesme Yönü Cutting Direction						
Sayfa (Page)	50	51	51	51	52	52
Takım Tipi (Tool Types)	SDUC	SDQC	SDXC	SVXC	SVUC	SVQC
Yanaşma Açısı (Touching Angle)	93°	107.5°	93°	93°	93°	107.5°
Kesme Yönü Cutting Direction						
Sayfa (Page)	53	53	54	54	55	55
Takım Tipi (Tool Types)	SVUB	SVQB	SSKC	SSSC	STFC	CKUN
Yanaşma Açısı (Touching Angle)	93°	107.5°	75°	45°	90°	93°
Kesme Yönü Cutting Direction						
Sayfa (Page)	56	56	57	57	58	58
Takım Tipi (Tool Types)	CSKP	CTFP	CSYN	CCLN	DCLN	DWLN
Yanaşma Açısı (Touching Angle)	75°	90°	85°	95°	95°	95°
Kesme Yönü Cutting Direction						
Sayfa (Page)	59	59	60	60	61	61
Takım Tipi (Tool Types)	DDUN	DTUN	SCLC	SDUC		
Yanaşma Açısı (Touching Angle)	93°	93°	95°	93°		
Kesme Yönü Cutting Direction						
Sayfa (Page)	62	62	63	63		

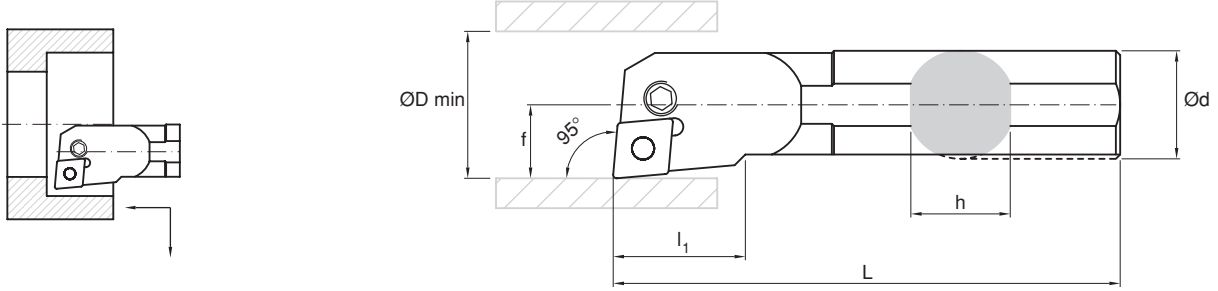

P Type - Lever System Boring Bars P Tip - Levye Sistem Delik Kateri





PCLN.....95°

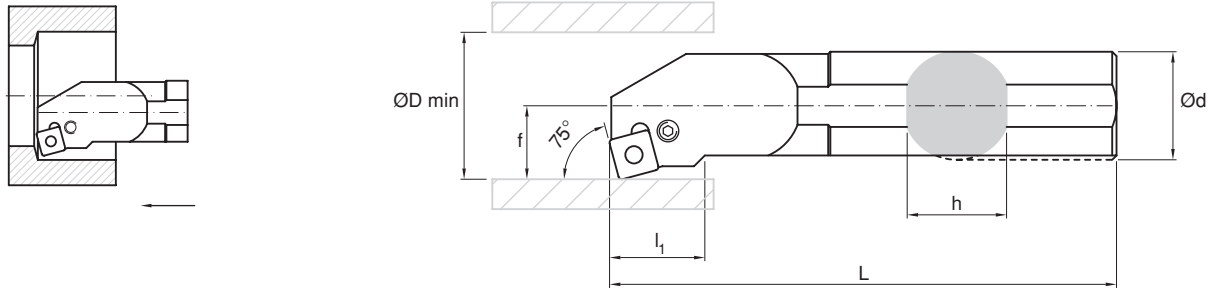

		DIMENSION KATER ÖLÇÜLERİ											
Ordering No. Takim Kod No.	Stock Stok		ØDmin	d	h	L	l ₁	f	Insert Kesici Uç	Shim Altılık	Lever Levye	Lever Screw Levye Vidası	Shim Spring Altılık Yayı
	R	L											
S 25 S PCLNR/L 12T	●	●	32	25	23	250	23	17	CNM...1204	—	438.3.841	438.3.832	—
S 32 T PCLNR/L 12T	●	●	40	32	30	300	26	22		U 112150	H 023441	S 023421	R 023461
S 40 U PCLNR/L 12T	○	○	50	40	37	350	26	27					
S 40 U PCLNR/L 16T	○	○	50	40	37	350	32	27	CNM...1606	U 000152	H 000840	S 028430	R 025464
S 50 W PCLNR/L 16T	○	○	63	50	47	450	32	35					

PSKN.....75°



		DIMENSION KATER ÖLÇÜLERİ											
Ordering No. Takim Kod No.	Stock Stok		ØDmin	d	h	L	l ₁	f	Insert Kesici Uç	Shim Altılık	Lever Levye	Lever Screw Levye Vidası	Shim Spring Altılık Yayı
	R	L											
S 25 S PSKNR/L 12T	○	○	32	25	23	250	23	17	SNM...1204	—	438.3.841	438.3.832	—
S 32 T PSKNR/L 12T	○	○	40	32	30	300	26	22		U 063451	H 023441	S 023421	R 023461
S 40 U PSKNR/L 12T	○	○	50	40	37	350	26	27					
S 40 U PSKNR/L 15T	○	○	50	40	37	350	32	27	SNM...1506	U 000457	H 000840	S 028430	R 025464
S 50 W PSKNR/L 15T	○	○	63	50	47	450	32	35					



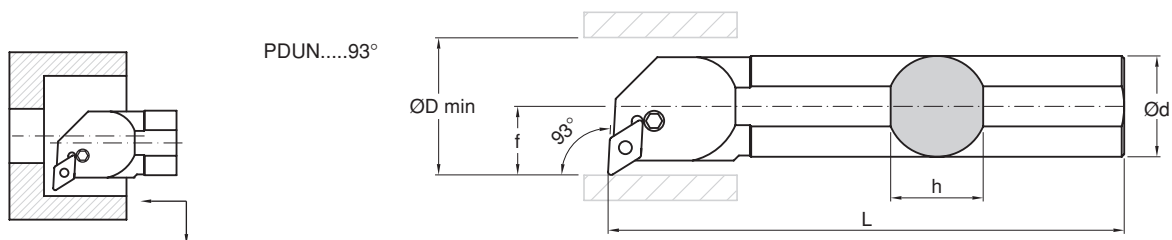

P Type - Lever System Boring Bars

P Tip - Levye Sistem Delik Kateri

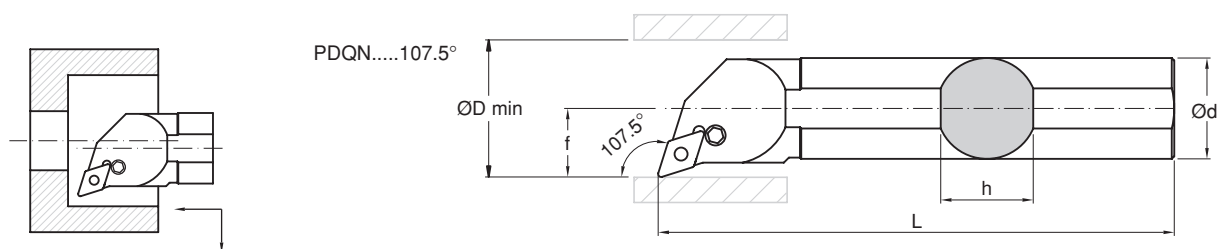





		DIMENSION KATER ÖLÇÜLERİ										
Ordering No. Takım Kod No.	Stock Stok		ØDmin	d	h	L	f	Insert Kesici Uç	Shim Altlık	Lever Levye	Lever Screw Levye Vidası	Shim Spring Altlık Yayı
	R	L										
S 16 R PDUNR/L 11	○	○	21	16	15	200	11	DNM...1104	—	H 019445	438.3.830	—
S 20 R PDUNR/L 11	○	○	25	20	18	200	13					
S 25 S PDUNR/L 11	○	○	32	25	23	250	17					
S 32 T PDUNR/L 15	●	○	40	32	30	300	22	DNM...1506	U 153150	H 024447	S 028430	R 023461
S 40 U PDUNR/L 15	○	○	50	40	37	350	27					
S 50 W PDUNR/L 15	○	○	63	50	47	450	35					

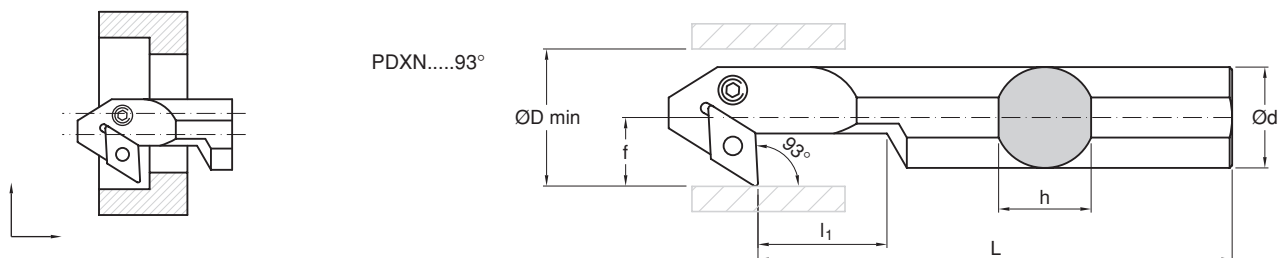

		DIMENSION KATER ÖLÇÜLERİ										
Ordering No. Takım Kod No.	Stock Stok		ØDmin	d	h	L	f	Insert Kesici Uç	Shim Altlık	Lever Levye	Lever Screw Levye Vidası	Shim Spring Altlık Yayı
	R	L										
S 32 T PDQNR/L 15	●	○	40	32	30	300	22	DNM...1506	U 153150	H 024447	S 028430	R 023461
S 40 U PDQNR/L 15	○	○	50	40	37	350	27					
S 50 W PDQNR/L 15	○	○	63	50	47	450	35					



		DIMENSION KATER ÖLÇÜLERİ											
Ordering No. Takım Kod No.	Stock Stok		ØDmin	d	h	L	l ₁	f	Insert Kesici Uç	Shim Altlık	Lever Levye	Lever Screw Levye Vidası	Shim Spring Altlık Yayı
	R	L											
S 32 T PDXNR/L 15	○	○	40	32	30	300	63	22	DNM...1506	U 153150	H 024447	S 028430	R 023461
S 40 U PDXNR/L 15	○	○	50	40	37	350	70	27					
S 50 W PDXNR/L 15	○	○	63	50	47	450	75	35					



● Stokta Mevcut / In stock

⦿ Siparişten sonra 2 hafta / 2 weeks upon the date of order



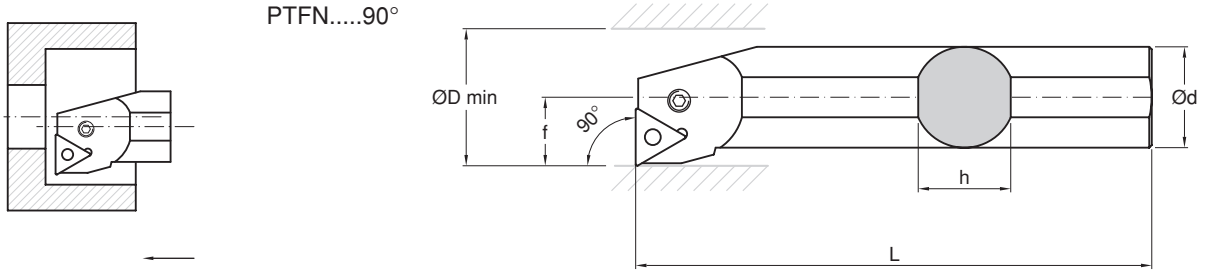

○ Siparişten sonra 4 hafta / 4 weeks upon the date of order

P Type - Lever System Boring Bars P Tip - Levye Sistem Delik Kateri

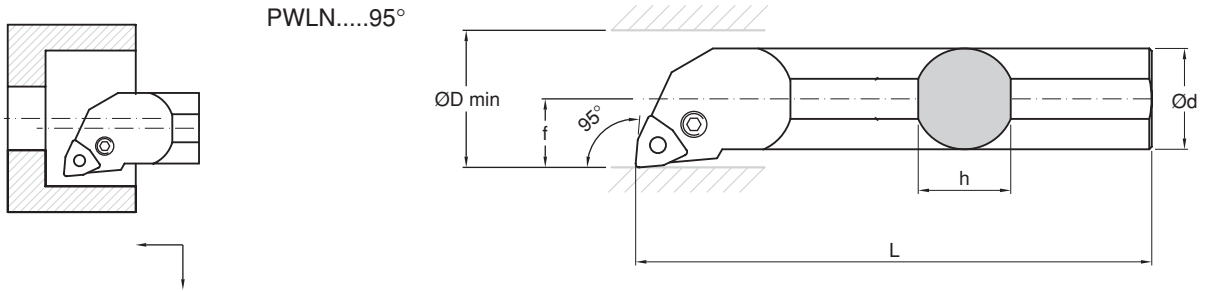

		DIMENSION KATER ÖLÇÜLERİ										
Ordering No. Takım Kod No.	Stock Stok		ØDmin	d	h	L	f	Insert Kesici Uç	Shim Altık	Lever Levye	Lever Screw Levye Vidası	Shim Spring Altık Yayı
	R	L										
S 25 S PTFNR/L 16	○	○	32	25	23	250	17	TNM...1604	—	5431.015.011	438.3.830	—
S 32 T PTFNR/L 16	○	○	40	32	30	300	22		U 013950	H 018440	S 018420	R 018463
S 40 U PTFNR/L 16	○	○	50	40	37	350	27					
S 40 U PTFNR/L 22	○	○	50	40	37	350	27	TNM...2204	U 023952	H 023441	S 023421	R 023461
S 50 W PTFNR/L 22	○	○	63	50	47	450	35					







		DIMENSION KATER ÖLÇÜLERİ										
Ordering No. Takım Kod No.	Stock Stok		ØDmin	d	h	L	f	Insert Kesici Uç	Shim Altık	Lever Levye	Lever Screw Levye Vidası	Shim Spring Altık Yayı
	R	L										
S 16 R PWLNR/L 06	○	○	21	16	15	200	11	WNM...0604	—	5432.015.011	438.3.832M	—
S 20 R PWLNR/L 06	○	○	25	20	18	200	13					
S 25 S PWLNR/L 06	○	○	32	25	23	250	17					
S 25 S PWLNR/L 08	●	○	32	25	23	250	17	WNM...0804	—	438.3.841	438.3.832M	—
S 32 T PWLNR/L 08	○	○	40	32	30	300	22		7853519	H 023441	S 023421	R 023451
S 40 T PWLNR/L 08	○	○	50	40	37	300	27					

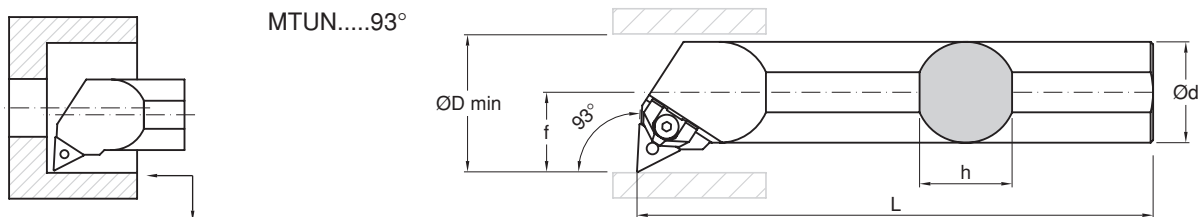



M Type - Clamping & Pim System Boring Bars

M Tip - Pabuçlu ve Pimli Sistem Delik Kateri

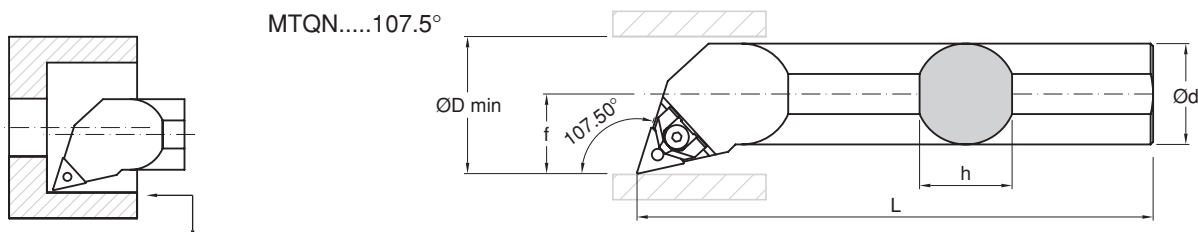





		DIMENSION KATER ÖLÇÜLERİ										
Ordering No. Takım Kod No.	Stock Stok		ØDmin	d	h	L	f	Insert Kesici Uç	Shim Altılık	Clamp Baskı Pabucu	Screw Baskı Vidası	Pim Pim
	R	L										
S 20 S MTUNR/L 16	○	○	25	20	19	200	13	TNM...1604	—	TMB 16	MTJN.16M5BV X	170.3.847 X
S 25 S MTUNR/L 16	●	○	32	25	23	250	17		—	170.3.820-1	MTJN.16M5BV	170.3.847 X
S 32 T MTUNR/L 16	●	○	40	32	30	300	22		170.3.852			170.3.847
S 40 U MTUNR/L 16	○	○	50	40	37	350	27					
S 32 T MTUNR/L 22	○	○	40	32	30	300	22	TNM...2204	170.3.856	170.3.821-1	MTJN.22M6BV	170.3.836
S 40 U MTUNR/L 22	○	○	50	40	37	350	27					
S 50 W MTUNR/L 22	○	○	63	50	47	450	35					

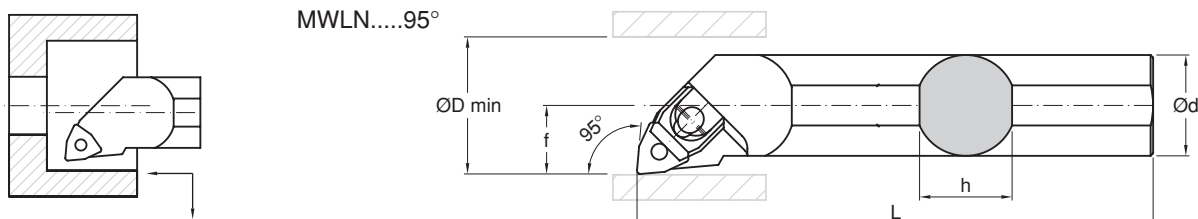

		DIMENSION KATER ÖLÇÜLERİ										
Ordering No. Takım Kod No.	Stock Stok		ØDmin	d	h	L	f	Insert Kesici Uç	Shim Altılık	Clamp Baskı Pabucu	Screw Baskı Vidası	Pim Pim
	R	L										
S 25 S MTQNR/L 16	○	○	32	25	23	250	17	TNM...1604	—	170.3.820-1	MTJN.16M5BV	—
S 32 T MTQNR/L 16	○	○	40	32	30	300	22		170.3.852			170.3.847
S 40 U MTQNR/L 16	○	○	50	40	37	350	27					
S 32 T MTQNR/L 22	○	○	40	32	30	300	22	TNM...2204			MTJN.22M6BV	170.3.836
S 40 U MTQNR/L 22	○	○	50	40	37	350	27		170.3.856	170.3.821-1		
S 50 W MTQNR/L 22	○	○	63	50	47	450	35					







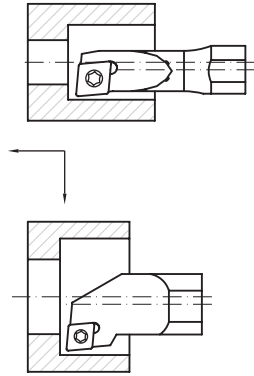

		DIMENSION KATER ÖLÇÜLERİ										
Ordering No. Takım Kod No.	Stock Stok		ØDmin	d	h	L	f	Insert Kesici Uç	Shim Altılık	Clamp Baskı Pabucu	Screw Baskı Vidası	Pim Pim
	R	L										
S 25 S MWLNR/L 08	●	○	32	25	23	250	17	WNM...0804	—	WN 08 BP	MTJN.22M6BV	—
S 32 T MWLNR/L 08	●	○	40	32	30	300	22		WN 08 ALT			170.3.836
S 40 U MWLNR/L 08	○	○	50	40	37	350	27					
S 50 W MWLNR/L 08	○	○	63	50	47	450	35					

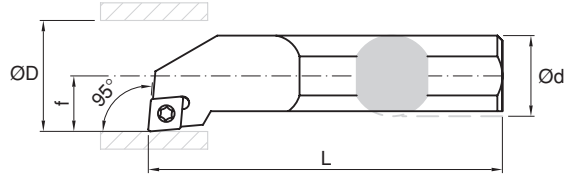
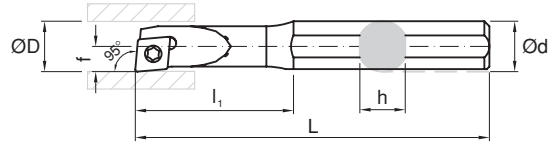
S Type - Screw System Boring Bars S Tip - Vidalı Sistem Delik Kateri



SCLC.....95°





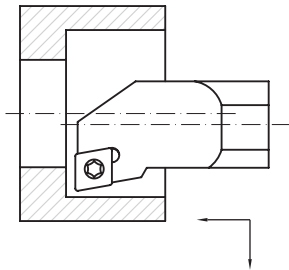

		DIMENSION KATER ÖLÇÜLERİ											
Ordering No. Takım Kod No.	Stock Stok	ØDmin	d	h	L	l ₁	f	Insert Kesici Uç	Shim Altık	Shim Screw Altık Vidası	Screw Sıkma Vidası	Wrench Torx Anahtar	
	R												L
S 06 08 H SCLCR/L 06	● ●	7.6	8	7	100	25	4	CCM..0602	—	—	7815101	T08	
S 08 10 H SCLCR/L 06	● ●	12	10	9	100	30	6						
S 10 12 K SCLCR/L 06	● ●	13.6	12	11	125	35	7						
S 12 16 M SCLCR/L 06	● ●	17.2	16	15	150	40	9						
S 16 R SCLCR/L 09	● ●	21	16	15	200	—	11	CCM..09T3	—	—	7883209	T15	
S 20 R SCLCR/L 09	● ●	25	20	18	200	—	13						
S 25 S SCLCR/L 09	○ ○	32	25	23	250	—	17						
S 32 T SCLCR/L 12	○ ○	40	32	30	300	—	22	CCM..1204	7883002	7883101	7883202	T15	
S 40 U SCLCR/L 12	○ ○	50	40	37	350	—	27						

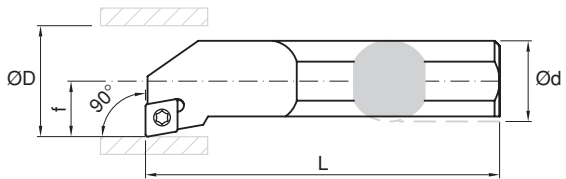

SCFC.....90°



		DIMENSION KATER ÖLÇÜLERİ											
Ordering No. Takım Kod No.	Stock Stok	ØDmin	d	h	L	f	Insert Kesici Uç	Shim Altık	Shim Screw Altık Vidası	Screw Sıkma Vidası	Wrench Torx Anahtar		
	R											L	
S 08 H SCFCR/L 06	○ ○	11	8	7	100	5	CCM..0602	—	—	7815101	T08		
S 10 K SCFCR/L 06	○ ○	13.6	10	9	125	7							
S 12 Q SCFCR/L 06	○ ○	17	12	11	180	9							
S 16 R SCFCR/L 09	○ ○	21	16	15	200	11	CCM..09T3	—	—	7883209	T15		
S 20 R SCFCR/L 09	○ ○	25	20	18	200	13							
S 25 S SCFCR/L 09	○ ○	32	25	23	250	17							
S 32 T SCFCR/L 12	○ ○	40	32	30	300	22	CCM..1204	7883002	7883101	7883202	T15		
S 40 U SCFCR/L 12	○ ○	50	40	37	350	27							

S Type - Screw System Boring Bars

S Tip - Vidalı Sistem Delik Kateri

SDUC.....93°

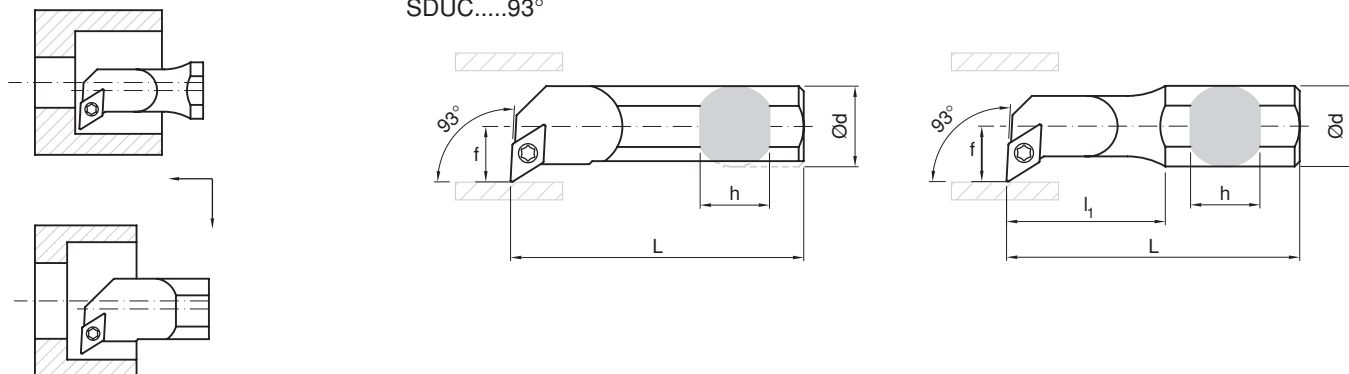

Ordering No. Takım Kod No.	Stock Stok		DIMENSION KATER ÖLÇÜLERİ						Insert Kesici Uç	Shim Altık	Shim Screw Altık Vidası	Screw Sıkma Vidası	Wrench Torx Anahtar
	R	L	ØDmin	d	h	L	l ₁	f					
S 08 10 H SDUCR/L 07	●	●	12	10	9	100	30	7	DCM..0702	—	—	7815101	T08
S 10 12 K SDUCR/L 07	●	●	13.6	12	11	125	35	9					
S 12 16 M SDUCR/L 07	●	●	17	16	15	150	40	11					
S 16 R SDUCR/L 07	○	○	21	16	15	200		11					
S 20 R SDUCR/L 07	○	○	25	20	18	200		13					
S 16 R SDUCR/L 11	●	○	21	16	15	200		11	DCM..11T3	—	—	7883209	T15
S 20 R SDUCR/L 11	●	●	25	20	18	200		13		7815000	7883102	7815102	
S 25 S SDUCR/L 11	●	●	32	25	23	250		17					
S 32 T SDUCR/L 11	○	○	40	32	30	300		22					
S 40 U SDUCR/L 11	○	○	50	40	37	350		27					

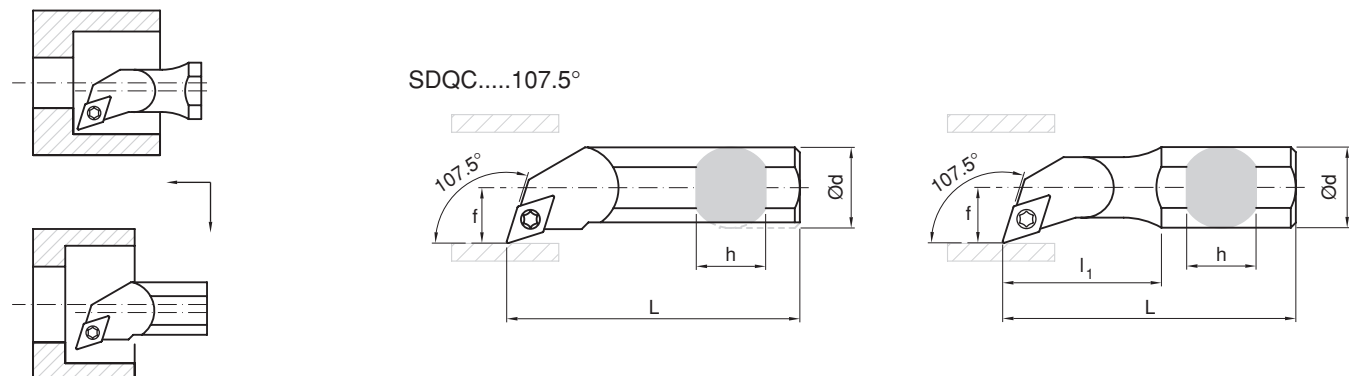

SDQC.....107.5°

Ordering No. Takım Kod No.	Stock Stok		DIMENSION KATER ÖLÇÜLERİ						Insert Kesici Uç	Shim Altık	Shim Screw Altık Vidası	Screw Sıkma Vidası	Wrench Torx Anahtar
	R	L	ØDmin	d	h	L	l ₁	f					
S 08 10 H SDQCR/L 07	●	●	12	10	9	100	30	7	DCM..0702	—	—	7815101	T08
S 10 12 K SDQCR/L 07	●	●	13.6	12	11	125	35	9					
S 12 16 M SDQCR/L 07	●	●	17	16	15	150	40	11					
S 16 R SDQCR/L 07	○	○	21	16	15	200		11					
S 20 R SDQCR/L 07	○	○	25	20	18	200		13					
S 16 R SDQCR/L 11	●	○	21	16	15	200		11	DCM..11T3	—	—	7883209	T15
S 20 R SDQCR/L 11	●	●	25	20	18	200		13		7815000	7883102	7815102	
S 25 S SDQCR/L 11	●	●	32	25	23	250		17					
S 32 T SDQCR/L 11	○	○	40	32	30	300		22					
S 40 U SDQCR/L 11	○	○	50	40	37	350		27					

● Stokta Mevcut / In stock





○ Siparişten sonra 2 hafta / 2 weeks upon the date of order

○ Siparişten sonra 4 hafta / 4 weeks upon the date of order

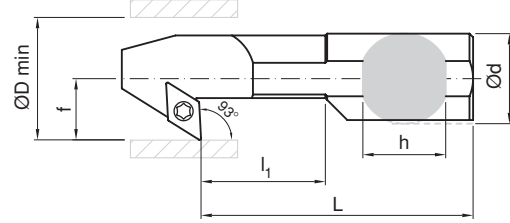
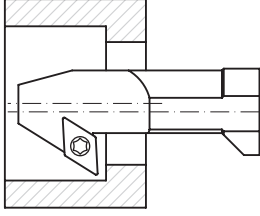
S Type - Screw System Boring Bars S Tip - Vidalı Sistem Delik Kateri

SDXC.....93°





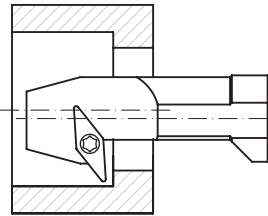

		DIMENSION KATER ÖLÇÜLERİ											
Ordering No. Takım Kod No.	Stock Stok		ØDmin	d	h	L	l ₁	f	Insert Kesici Uç	Shim Altık	Shim Screw Altık Vidası	Screw Sıkma Vidası	Wrench Torx Anahtar
	R	L											
S 12 Q SDXCR/L 07	○	○	17	12	11	180	30	9	DCM..0702	—	—	7815101	T08
S 16 R SDXCR/L 07	○	○	21	16	15	200	35	11					
S 20 R SDXCR/L 07	○	○	25	20	18	200	40	13					
S 20 R SDXCR/L 11	○	○	25	20	18	200	40	13	DCM..11T3	—	—	7883209	T15
S 25 S SDXCR/L 11	○	○	32	25	23	250	55	17		7815000	7883102	7815102	
S 32 T SDXCR/L 11	○	○	40	32	30	300	63	22					
S 40 U SDXCR/L 11	○	○	50	40	37	350	70	27					

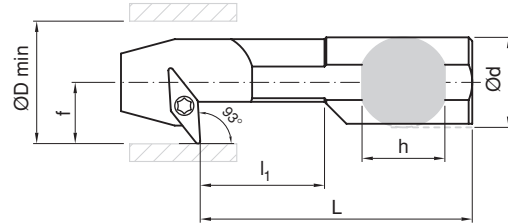

SVXC.....93°







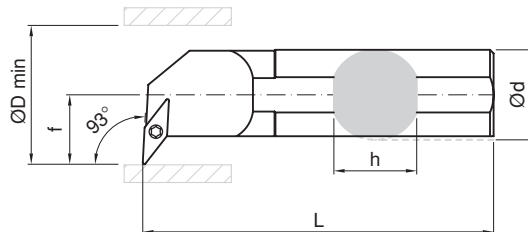
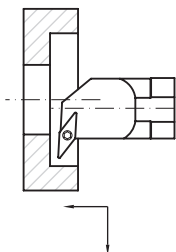

		DIMENSION KATER ÖLÇÜLERİ											
Ordering No. Takım Kod No.	Stock Stok		ØDmin	d	h	L	l ₁	f	Insert Kesici Uç	Shim Altık	Shim Screw Altık Vidası	Screw Sıkma Vidası	Wrench Torx Anahtar
	R	L											
S 16 R SVXCR/L 11	○	○	22	16	15	200	35	13	VCM..1103	—	—	7815101	T08
S 20 R SVXCR/L 11	○	○	25	20	18	200	40	16					
S 25 S SVXCR/L 11	○	○	32	25	23	250	45	18					
S 25 S SVXCR/L 16	○	○	32	25	23	250	55	18	VCM..1604	—	—	7815102	T15
S 32 T SVXCR/L 16	○	○	40	32	30	300	63	22		7815002	7883102		
S 40 U SVXCR/L 16	○	○	50	40	37	350	70	27					

S Type - Screw System Boring Bars

S Tip - Vidalı Sistem Delik Kateri

SVUC.....93°





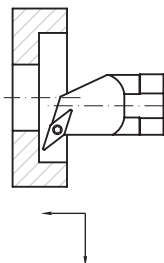

		DIMENSION KATER ÖLÇÜLERİ										
Ordering No. Takım Kod No.	Stock Stok		ØDmin	d	h	L	f	Insert Kesici Uç	Shim Altılık	Shim Screw Altılık Vidası	Screw Sıkma Vidası	Wrench Torx Anahtar
	R	L										
S 16 R SVUCR/L 11	○	○	21	16	15	200	11	VCM..1103	—	—	7815101	T08
S 20 R SVUCR/L 11	○	○	25	20	18	200	13					
S 25 S SVUCR/L 16	●	○	32	25	23	250	17	VCM..1604	—	—	7815102	T15
S 32 T SVUCR/L 16	●	○	40	32	30	300	22		7815002	7883102		
S 40 U SVUCR/L 16	○	○	50	40	37	350	27					

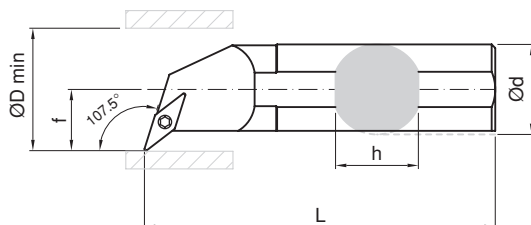

SVQC.....107.5°



		DIMENSION KATER ÖLÇÜLERİ										
Ordering No. Takım Kod No.	Stock Stok		ØDmin	d	h	L	f	Insert Kesici Uç	Shim Altılık	Shim Screw Altılık Vidası	Screw Sıkma Vidası	Wrench Torx Anahtar
	R	L										
S 16 R SVQCR/L 11	○	○	21	16	15	200	11	VCM..1103	—	—	7815101	T08
S 20 R SVQCR/L 11	○	○	25	20	18	200	13					
S 25 S SVQCR/L 16	●	○	32	25	23	250	17	VCM..1604	—	—	7815102	T15
S 32 T SVQCR/L 16	●	○	40	32	30	300	22		7815002	7883102		
S 40 U SVQCR/L 16	○	○	50	40	37	350	27					

● Stokta Mevcut / In stock

● Siparişten sonra 2 hafta / 2 weeks upon the date of order

○ Siparişten sonra 4 hafta / 4 weeks upon the date of order

S Type - Screw System Boring Bars S Tip - Vidalı Sistem Delik Kateri

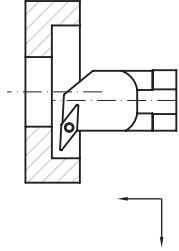

SVUB.....93°

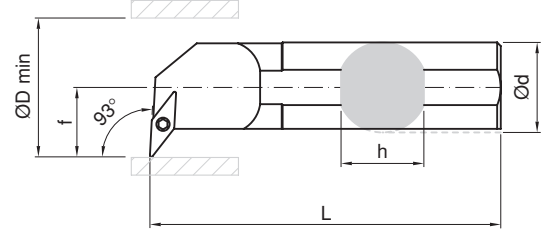

Ordering No. Takım Kod No.	Stock Stok		DIMENSION KATER ÖLÇÜLERİ					Insert Kesici Uç	Shim Altık	Shim Screw Altık Vidası	Screw Sıkma Vidası	Wrench Torx Anahtar
	R	L	ØDmin	d	h	L	f					
S 16 R SVUBR/L 11	○	○	21	16	15	200	11	VBM..1103	—	—	7815101	T08
S 20 R SVUBR/L 11	○	○	25	20	18	200	13					
S 25 S SVUBR/L 16	○	○	32	25	23	250	17	VBM..1604	—	—	7815102	T15
S 32 T SVUBR/L 16	○	○	40	32	30	300	22		7815002	7883102		
S 40 U SVUBR/L 16	○	○	50	40	37	350	27					

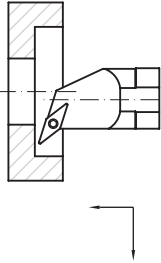

SVQB.....107.5°

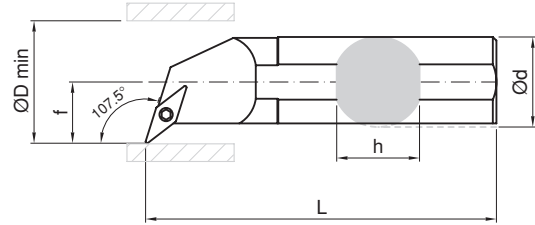

Ordering No. Takım Kod No.	Stock Stok		DIMENSION KATER ÖLÇÜLERİ					Insert Kesici Uç	Shim Altık	Shim Screw Altık Vidası	Screw Sıkma Vidası	Wrench Torx Anahtar
	R	L	ØDmin	d	h	L	f					
S 16 R SVQBR/L 11	○	○	21	16	15	200	11	VBM..1103	—	—	7815101	T08
S 20 R SVQBR/L 11	○	○	25	20	18	200	13					
S 25 S SVQBR/L 16	○	○	32	25	23	250	17	VBM..1604	—	—	7815102	T15
S 32 T SVQBR/L 16	○	○	40	32	30	300	22		7815002	7883102		
S 40 U SVQBR/L 16	○	○	50	40	37	350	27					

S Type - Screw System Boring Bars

S Tip - Vidalı Sistem Delik Kateri

SSKC.....75°

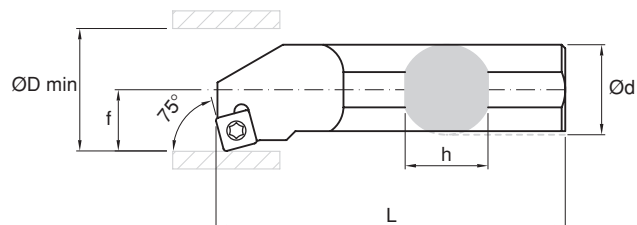
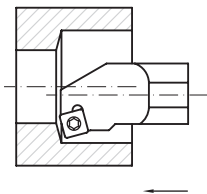

Ordering No. Takım Kod No.	Stock Stok		DIMENSION KATER ÖLÇÜLERİ					Insert Kesici Uç	Shim Altık	Shim Screw Altık Vidası	Screw Sıkma Vidası	Wrench Torx Anahtar
	R	L	ØDmin	d	h	L	f					
S 16 R SSKCR/L 09	●	○	21	16	15	200	11	SCM..09T3	—	—	7815102	T15
S 20 R SSKCR/L 09	●	○	25	20	18	200	13					
S 25 S SSKCR/L 09	○	○	32	25	23	250	17					
S 25 S SSKCR/L 12	○	○	32	25	23	250	17	SCM..1204	—	—	7883202	T15
S 32 T SSKCR/L 12	○	○	40	32	30	300	22		7883004	7883101		
S 40 U SSKCR/L 12	○	○	50	40	37	350	27					

SSSC.....45°

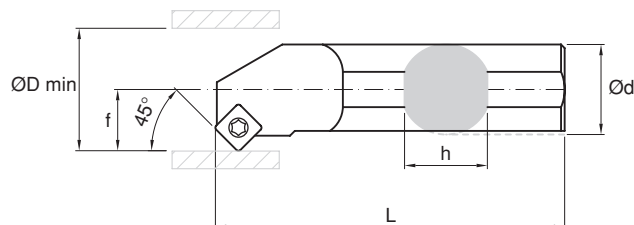
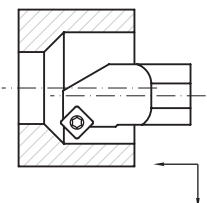

Ordering No. Takım Kod No.	Stock Stok		DIMENSION KATER ÖLÇÜLERİ					Insert Kesici Uç	Shim Altık	Shim Screw Altık Vidası	Screw Sıkma Vidası	Wrench Torx Anahtar
	R	L	ØDmin	d	h	L	f					
S 16 R SSSCR/L 09	●	○	21	16	15	200	11	SCM..09T3	—	—	7883209	T15
S 20 R SSSCR/L 09	●	○	25	20	18	200	13					
S 25 S SSSCR/L 09	○	○	32	25	23	250	17					
S 25 S SSSCR/L 12	○	○	32	25	23	250	17	SCM..1204	—	—	7883202	T15
S 32 T SSSCR/L 12	○	○	40	32	30	300	22		7883004	7883101		
S 40 U SSSCR/L 12	○	○	50	40	37	350	27					

● Stokta Mevcut / In stock





● Siparişten sonra 2 hafta / 2 weeks upon the date of order

○ Siparişten sonra 4 hafta / 4 weeks upon the date of order

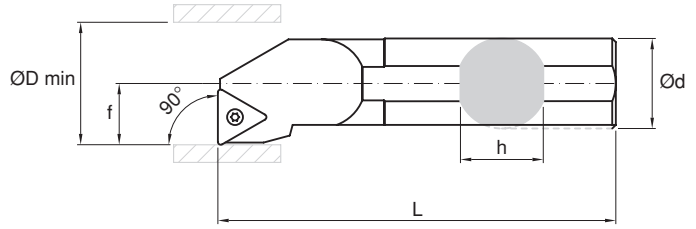
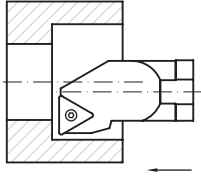
S Type - Screw System Boring Bars S Tip - Vidalı Sistem Delik Kateri

STFC.....90°







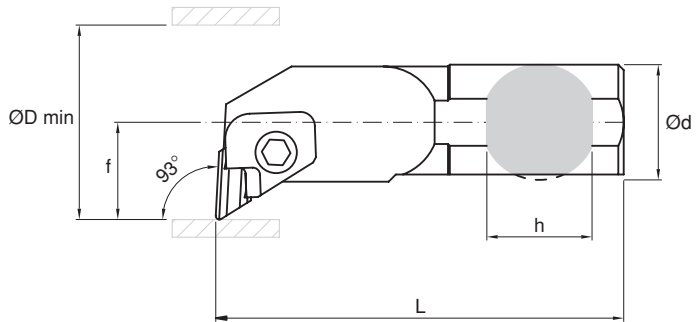
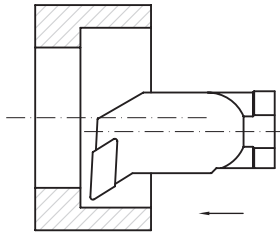

		DIMENSION KATER ÖLÇÜLERİ										
Ordering No. Takım Kod No.	Stock Stok		ØDmin	d	h	L	f	Insert Kesici Uç	Shim Altık	Shim Screw Altık Vidası	Screw Sıkma Vidası	Wrench Torx Anahtar
	R	L										
S 10 K STFCR/L 09	○	○	13.6	10	9	125	7	TCM..0902	—	—	7722113	T07
S 10 K STFCR/L 11	○	○	13.6	10	9	125	7	TCM..1102	—	—	7815101	T08
S 12 Q STFCR/L 11	●	○	17	12	11	180	9					
S 16 R STFCR/L 11	○	○	21	16	15	200	11					
S 20 R STFCR/L 11	○	○	25	20	18	200	13					
S 16 R STFCR/L 16	○	○	21	16	15	200	11	TCM..16T3	—	—	7815102	T15
S 20 R STFCR/L 16	●	○	25	20	18	200	13		—	—		
S 25 S STFCR/L 16	●	○	32	25	23	250	17		7883005	7883102		
S 32 T STFCR/L 16	○	○	40	32	30	300	22					
S 40 U STFCR/L 16	○	○	50	40	37	350	27					

C Tip - Pabuçlu Sistem Delik Kateri C Type - Clamping System Boring Bars

CKUN.....93°



		DIMENSION KATER ÖLÇÜLERİ												
Ordering No. Takım Kod No.	Stock Stok		ØDmin	d	h	L	f	Insert Kesici Uç	Rigth Clamp Sağ Baskı Parçası	Left Clamp Sol Baskı Parçası	Screw Baskı Vidası	Rigth Shim Sağ Altık	Left Shim Sol Altık	Shim Pin Altık Pimi
	R	L												
S 25 T CKUNR/L 16	●	○	32	25	23	300	17	KNUX 16...	70.5.824	70.5.825	70.5.865	—	—	—
S 32 U CKUNR/L 16	●	○	40	32	30	350	22					U 00051R	U 00051L	7480901
S 40 V CKUNR/L 16	○	○	50	40	37	400	27							
S 50 W CKUNR/L 16	○	○	63	50	47	450	35							





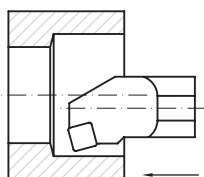

C Type - Clamping System Boring Bars

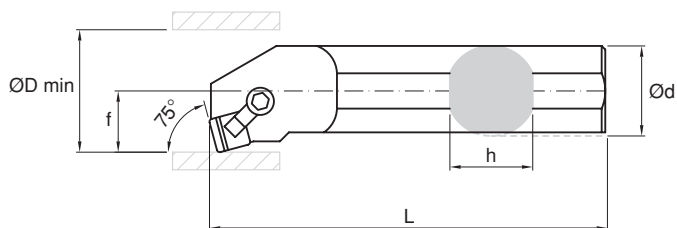
C Tip - Pabuçlu Sistem Delik Kateri



CSKP.....75°





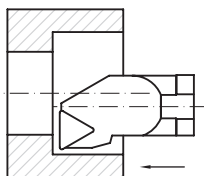

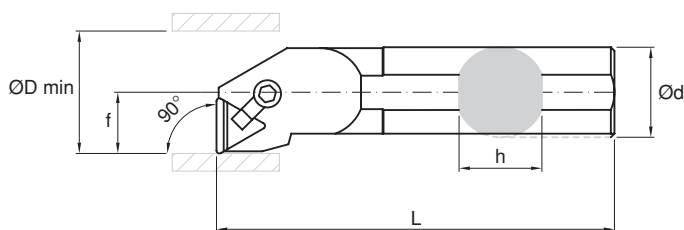

		DIMENSION KATER ÖLÇÜLERİ											
Ordering No. Takım Kod No.	Stock Stok		ØDmin	d	h	L	f	Insert Kesici Uç	Shim Altlık	Clamp Baskı Pabucu	Screw Baskı Vidası	Shim Pim Altlık Pimi	Sawdust Cutting Talaş Kırıcı
	R	L											
S 12 Q CSKPR/L 09	○	○	17	12	11	180	9	SP...0903..	—	7830001	7830002	—	—
S 16 R CSKPR/L 09	○	○	21	16	15	200	11						
S 20 R CSKPR/L 09	○	○	25	20	18	200	13						
S 25 S CSKPR/L 12	○	○	32	25	23	250	17	SP...1203..	7480315	TBP 16	TBP 16 BV	7480901	SP 12 TK
S 32 T CSKPR/L 12	○	○	40	32	30	300	22						
S 40 U CSKPR/L 12	○	○	50	40	37	350	27						



CTFP.....90°



		DIMENSION KATER ÖLÇÜLERİ											
Ordering No. Takım Kod No.	Stock Stok		ØDmin	d	h	L	f	Insert Kesici Uç	Shim Altlık	Clamp Baskı Pabucu	Screw Baskı Vidası	Shim Pim Altlık Pimi	Sawdust Cutting Talaş Kırıcı
	R	L											
S 12 Q CTFPR/L 11	●	○	17	12	11	180	9	TP...1103..	—	7830001	7830002	—	—
S 16 R CTFPR/L 11	●	○	21	16	15	200	11						
S 20 R CTFPR/L 11	●	○	25	20	18	200	13						
S 20 R CTFPR/L 16	●	○	25	20	18	200	13	TP...1603..	—	TBP 16	TBP 16 BV	—	TP 16 TK
S 25 S CTFPR/L 16	○	○	32	25	23	250	17		7480316			7480901	
S 32 T CTFPR/L 16	○	○	40	32	30	300	22						
S 40 U CTFPR/L 16	○	○	50	40	37	350	27						
S 40 U CTFPR/L 22	○	○	50	40	37	350	27	TP...2204..	175.11.624	TBP 12	TBP 12 BV	M4 AV	TP 22 TK
S 50 W CTFPR/L 22	○	○	63	50	47	450	35						

● Stokta Mevcut / In stock





○ Siparişten sonra 2 hafta / 2 weeks upon the date of order

○ Siparişten sonra 4 hafta / 4 weeks upon the date of order

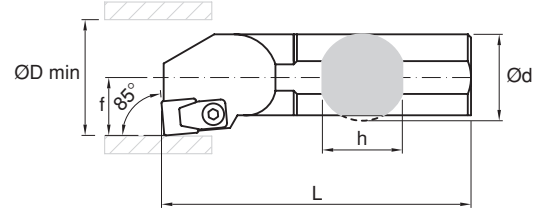
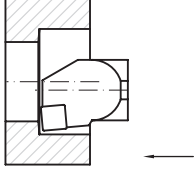
C Type - Clamping System Ceramic Boring Bars C Tip - Pabuçlu Sistem Seramik Delik Kateri







CSYN.....85°

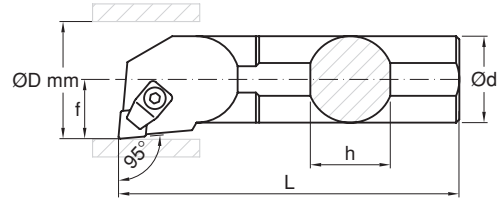
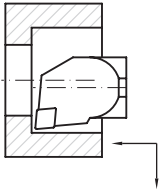

		DIMENSION KATER ÖLÇÜLERİ												
Ordering No. Takım Kod No.	Stock Stok		ØDmin	d	h	L	f	Insert Kesici Uç	Thin Shim İnce Altlık	Insert Kesici Uç	Thick Shim Kalın Altlık	Shim Screw Altılık Vidası	Clamp Baskı Pabucu	Screw Baskı Vidası
	R	L												
CSYNR/L 0040 T12S	○	○	55	40	37	300	27	SNG...1208...	SR 12 ALT	SNG...1204..	SR 12 AL2	M4 x 12 AV	70.91.11.094.0	70.91.11 BV
CSYNR/L 0050 U12S	○	○	65	50	47	350	35							
CSYNR/L 0063 V12S	○	○	75	63	60	400	43							

CCLN.....95°







		DIMENSION KATER ÖLÇÜLERİ												
Ordering No. Takım Kod No.	Stock Stok		ØDmin	d	h	L	f	Insert Kesici Uç	Thin Shim İnce Altlık	Insert Kesici Uç	Thick Shim Kalın Altlık	Shim Screw Altılık Vidası	Clamp Baskı Pabucu	Screw Baskı Vidası
	R	L												
CCLNR/L 0040 T12S	○	○	55	40	37	300	27	CNG....1208...	SRD 12 ALT	CNG....1208...	SRD 12 AL2	M4 x 12 AV	70.91.11.134.0	70.91.11.BV
CCLNR/L 0050 U12S	○	○	65	50	47	350	35							
CCLNR/L 0063 V12S	○	○	75	63	60	400	43							

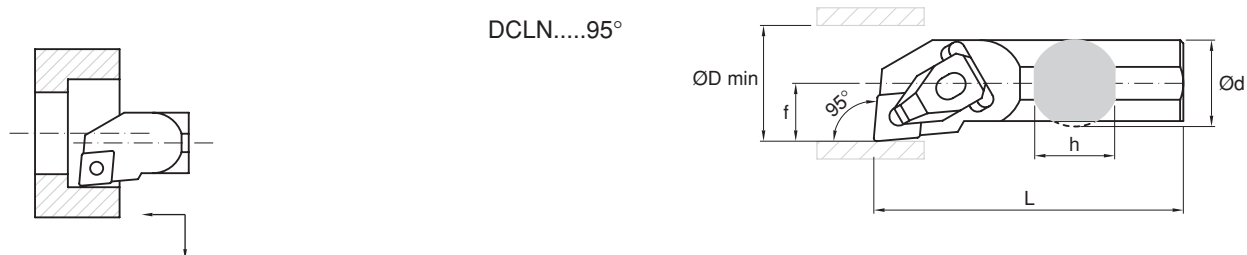



D Type - Clamping System Boring Bars

D Tip - Pabuçlu Sistem Delik Kateri

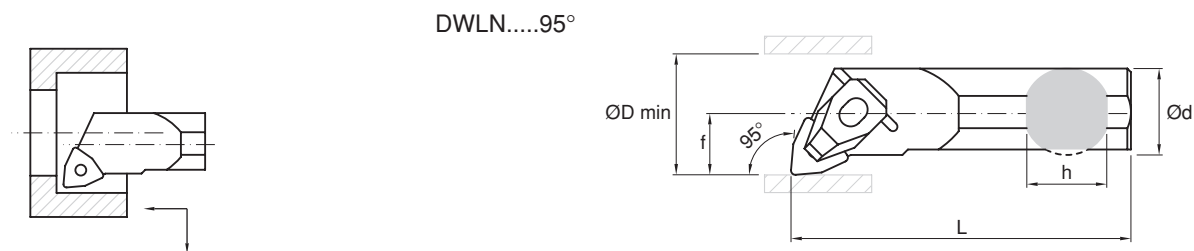

		DIMENSION KATER ÖLÇÜLERİ										
Ordering No. Takım Kod No.	Stock Stok		ØDmin	d	h	L	f	Insert Kesici Uç	Shim Altık	Clamp Baskı Pabucu	Screw Baskı Vidası	Screw Altık Vidası
	R	L										
S 25 S DCLNR/L 12T	○	○	32	25	23	250	17	CNM...1204	U 112150	TK DBP	MTJN.22M6BV	M4 AV
S 32 T DCLNR/L 12T	○	○	40	32	30	300	22					
S 40 U DCLNR/L 12T	○	○	50	40	37	350	27					



		DIMENSION KATER ÖLÇÜLERİ										
Ordering No. Takım Kod No.	Stock Stok		ØDmin	d	h	L	f	Insert Kesici Uç	Shim Altık	Clamp Baskı Pabucu	Screw Baskı Vidası	Screw Altık Vidası
	R	L										
S 25 S DWLNR/L 08T	○	○	32	25	23	250	17	WNM...0804	7853519	TK DBP	MTJN.22M6BV	M4 AV
S 32 T DWLNR/L 08T	○	○	40	32	30	300	22					
S 40 U DWLNR/L 08T	○	○	50	40	37	350	27					





● Stokta Mevcut / In stock

⌚ Siparişten sonra 2 hafta / 2 weeks upon the date of order

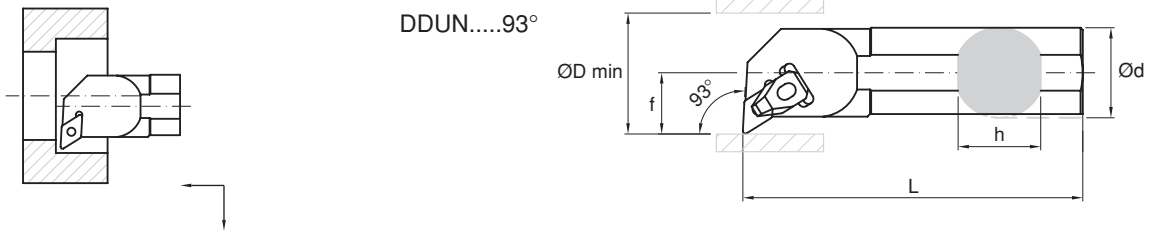



○ Siparişten sonra 4 hafta / 4 weeks upon the date of order

D Type - Clamping System Boring Bars D Tip - Pabuçlu Sistem Delik Kateri

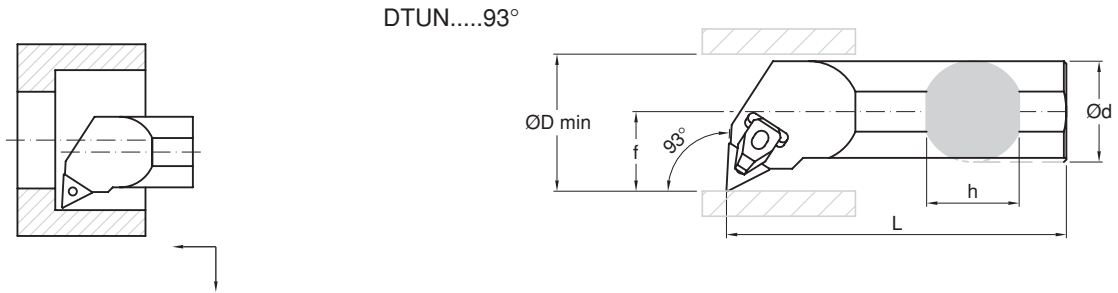

		DIMENSION KATER ÖLÇÜLERİ										
Ordering No. Takım Kod No.	Stock Stok		ØDmin	d	h	L	f	Insert Kesici Uç	Shim Altılık	Clamp Baskı Pabucu	Screw Baskı Vidası	Screw Altılık Vidası
	R	L										
S 25 S DDUNR/L 15T	●	○	32	25	23	250	17	DNM...1506	U 153150	TK DBP	MTJN.22M6BV	M4 AV
S 32 T DDUNR/L 15T	●	○	40	32	30	300	22					
S 40 U DDUNR/L 15T	○	○	50	40	37	350	27					







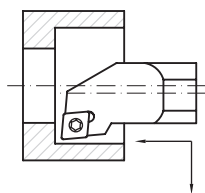

		DIMENSION KATER ÖLÇÜLERİ										
Ordering No. Takım Kod No.	Stock Stok		ØDmin	d	h	L	f	Insert Kesici Uç	Shim Altılık	Clamp Baskı Pabucu	Screw Baskı Vidası	Screw Altılık Vidası
	R	L										
S 25 S DTUNR/L 16T	○	○	32	25	23	250	17	TNM...1604	U 013950	TK DBP K	MTJN.22M6BV	M4 AV
S 32 T DTUNR/L 16T	○	○	40	32	30	300	22					
S 40 U DTUNR/L 16T	○	○	50	40	37	350	27					

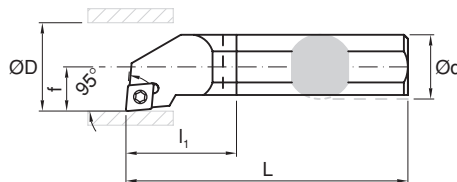
S Type - Screw System Carbur Shaft Boring Bars C Tip - Vidalı Sistem Karbür Şaftlı Delik Kateri



SCLC....95°





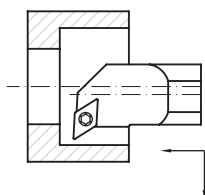

		DIMENSION KATER ÖLÇÜLERİ											
Ordering No. Takım Kod No.	Stock Stok	ØDmin	d	h	L	l ₁	f	Insert Kesici Uç	Shim Altlık	Shim Screw Altlık Vidası	Screw Sıkma Vidası	Wrench Torx Anahtar	
	R												L
E 08 K SCLCR/L 06	● ●	11	8	7	125	20	5	CCM..0602	—	—	7815101	T08	
E 10 K SCLCR/L 06	● ●	13.6	10	9	125	20	7						
E 12 Q SCLCR/L 06	● ●	17	12	11	180	20	9						
E 16 R SCLCR/L 06	● ●	21	16	15	200	25	11						
E 16 R SCLCR/L 09	● ●	21	16	15	200	30	11	CCM..09T3	—	—	7883209	T15	
E 20 S SCLCR/L 09	● ●	25	20	18	250	40	13						
E 25 T SCLCR/L 09	● ●	32	25	23	300	40	17						

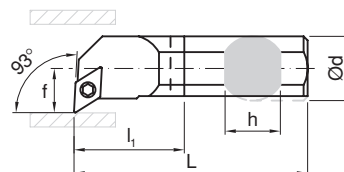

SDUC....93°



		DIMENSION KATER ÖLÇÜLERİ											
Ordering No. Takım Kod No.	Stock Stok	ØDmin	d	h	L	l ₁	f	Insert Kesici Uç	Shim Altlık	Shim Screw Altlık Vidası	Screw Sıkma Vidası	Wrench Torx Anahtar	
	R												L
E 08 K SDUCR/L 07	● ●	12	8	7	125	20	7	DCM..0702	—	—	7815101	T08	
E 10 K SDUCR/L 07	● ●	13.6	10	9	125	20	9						
E 12 Q SDUCR/L 07	● ●	17	12	11	180	20	11						
E 16 R SDUCR/L 07	● ●	21	16	15	200	25	11						
E 20 S SDUCR/L 07	● ●	25	20	18	250	30	13						
E 20 S SDUCR/L 11	● ●	25	20	18	250	40	13	DCM..11T3	—	—	7883209	T15	
E 25 T SDUCR/L 11	● ●	32	25	23	300	40	17		7815000	7883102	7815102		

● Stokta Mevcut / In stock

● Siparişten sonra 2 hafta / 2 weeks upon the date of order

○ Siparişten sonra 4 hafta / 4 weeks upon the date of order

Two Section Internal and External Turning Toolholder İki Yönlü İç ve Dış Torna Kateri

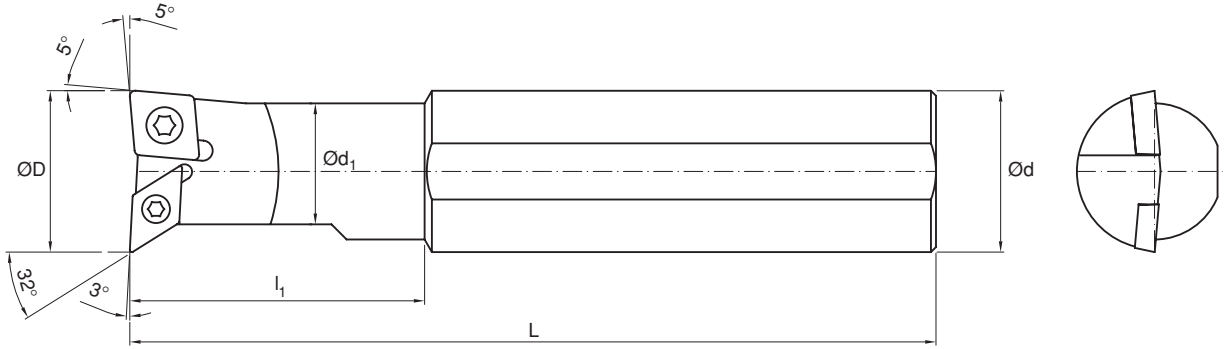

Ordering No. Takım Kod No.	Stock Stok	DIMENSION KATER ÖLÇÜLERİ						Insert Kesici Uç	Screw Sıkma Vidası	Insert Kesici Uç	Screw Sıkma Vidası	Wrench Torx Anahtar
		ØD	Ød ₁	Ød	l ₁	L	ØDmax					
S 20 Q SCR - SDL 06 - 07	○	20	16	20	45	180	24	CCM..0602	7815101	DCM..0702	7815101	T08
S 20 Q SDR - SCL 07 - 06	○	20	16	20	45	180	24					
S 22 R SCR - SDL 09 - 07	○	22	18	25	50	200	28	CCM..09T3	7883209	DCM..0702	7815101	T15 - T08
S 22 R SDR - SCL 07 - 09	○	22	18	25	50	200	28					
S 29 S SCR - SDL 09 - 11	○	29	22	32	70	250	32	CCM..09T3	7883209	DCM..11T3	7883209	T15
S 29 S SDR - SCL 11 - 09	○	29	22	32	70	250	32					
S 32 T SCR - SDL 12 - 11	○	32	27	32	85	300	37	CCM..1204	7883202	DCM..11T3	7883209	T15
S 32 T SDR - SCL 11 - 12	○	32	27	32	85	300	37					

Processing Flow / İşleme Şekli

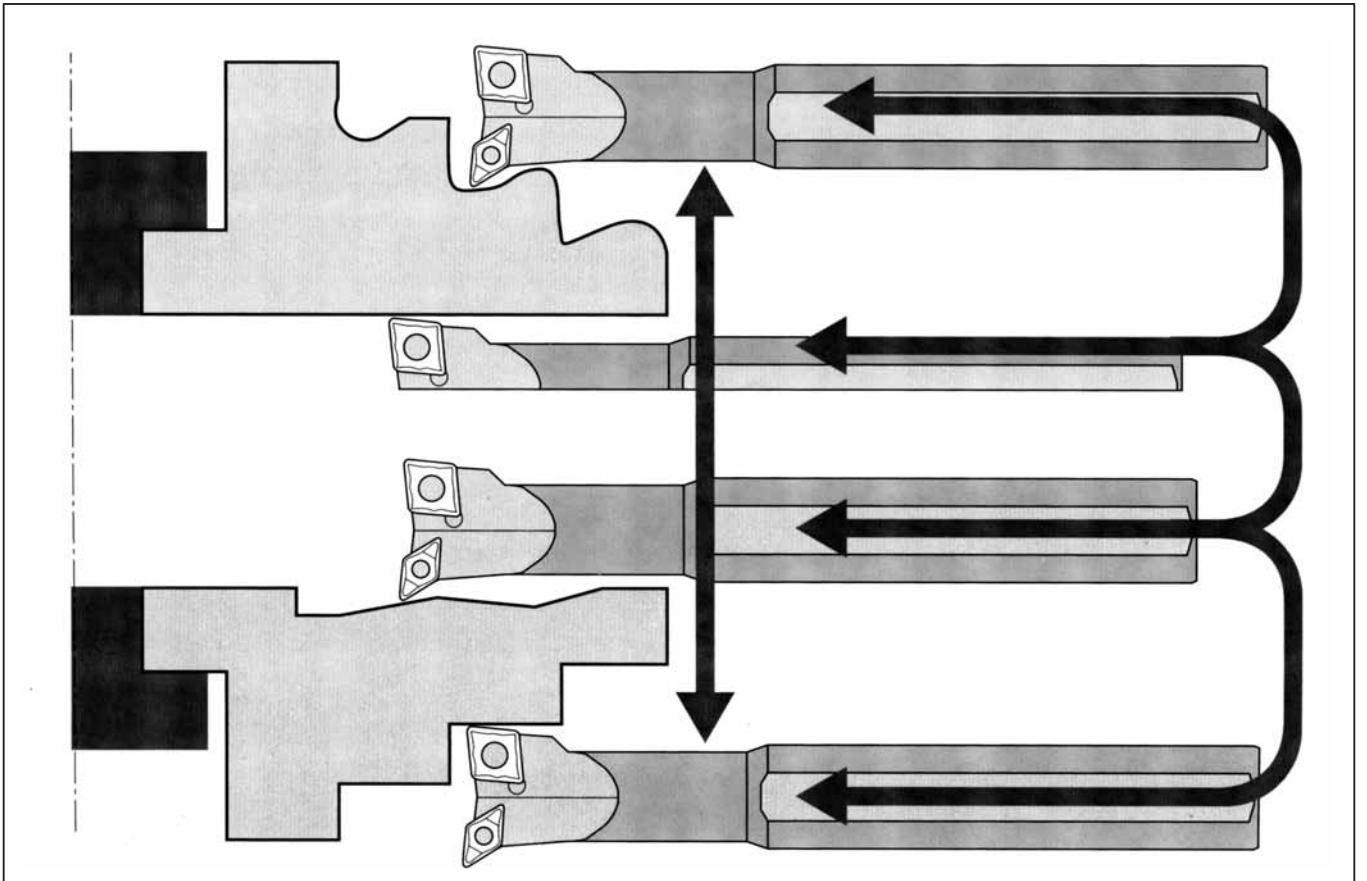

Two Section Internal and External Turning Toolholderö İki Yönlü İç ve Dış Torna Kateri

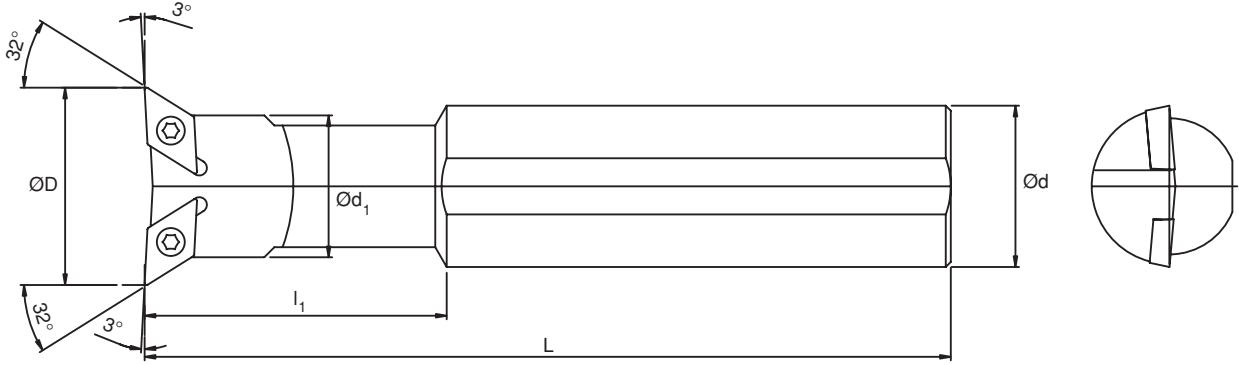

Ordering No. Takım Kod No.	Stock Stok	DIMENSION KATER ÖLÇÜLERİ						Insert Kesici Uç	Screw Sıkma Vidası	Insert Kesici Uç	Screw Sıkma Vidası	Wrench Torx Anahtar
		ØD	Ød ₁	Ød	l ₁	L	ØDmax					
S 18 Q SDR - SDL 07 - 07	○	18	13	20	45	180	24	DCM..0702	7815101	DCM..0702	7815101	T08
S 22 R SDR - SDL 07 - 07	○	22	15.5	20	50	200	26					
S 25 S SDR - SDL 07 - 07	○	25	19	25	60	250	30					
S 28 S SDR - SDL 11 - 11	○	28	23	32	70	250	34	DCM..11T3	7883209	DCM..11T3	7883209	T15
S 34 T SDR - SDL 11 - 11	○	34	27	32	85	300	38					

Processing Flow / İşleme Şekli

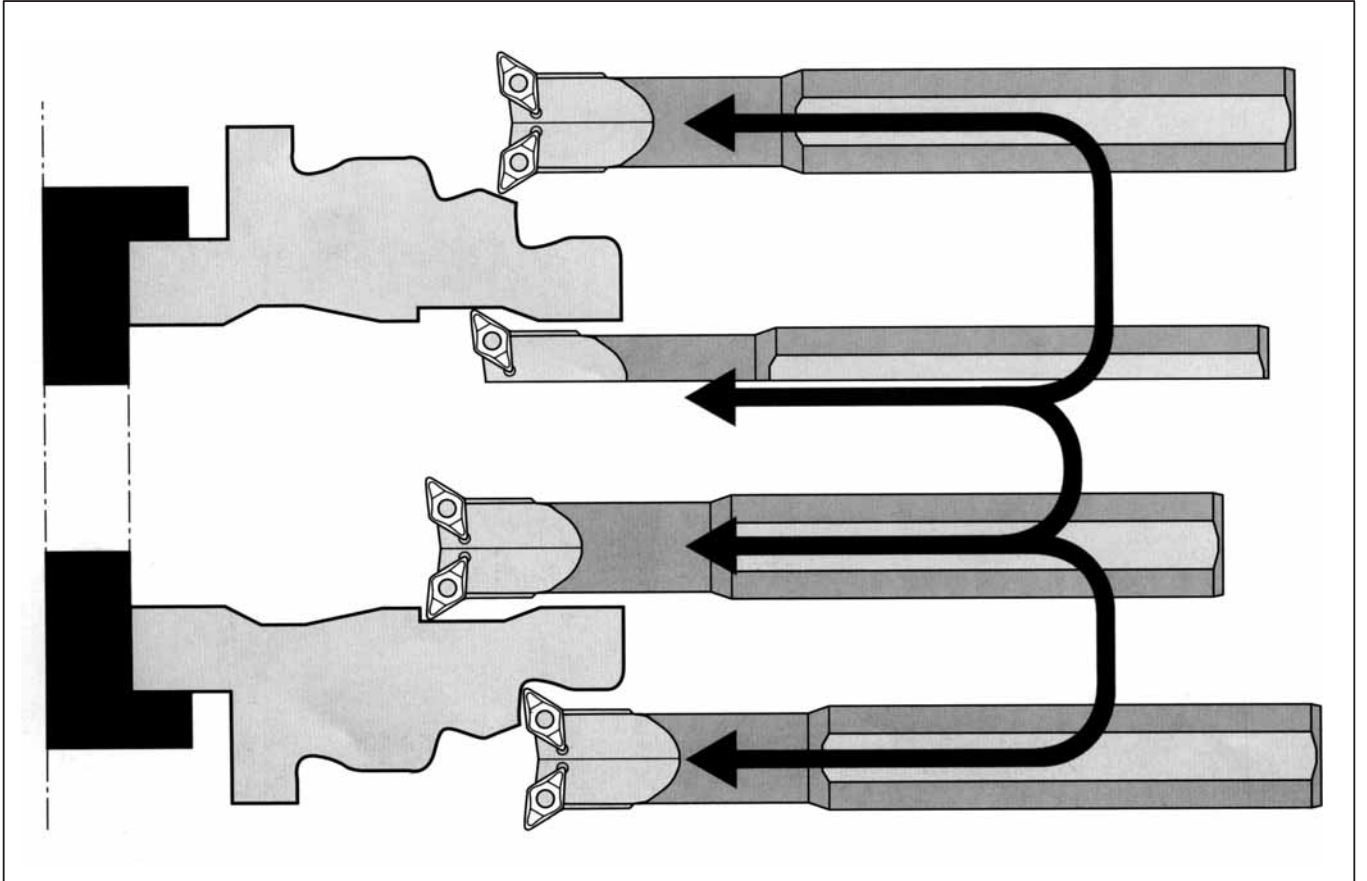

● Stokta Mevcut / In stock

● Siparişten sonra 2 hafta / 2 weeks upon the date of order

○ Siparişten sonra 4 hafta / 4 weeks upon the date of order

Two Section Internal and External Turning Toolholder İki Yönlü İç ve Dış Torna Kateri

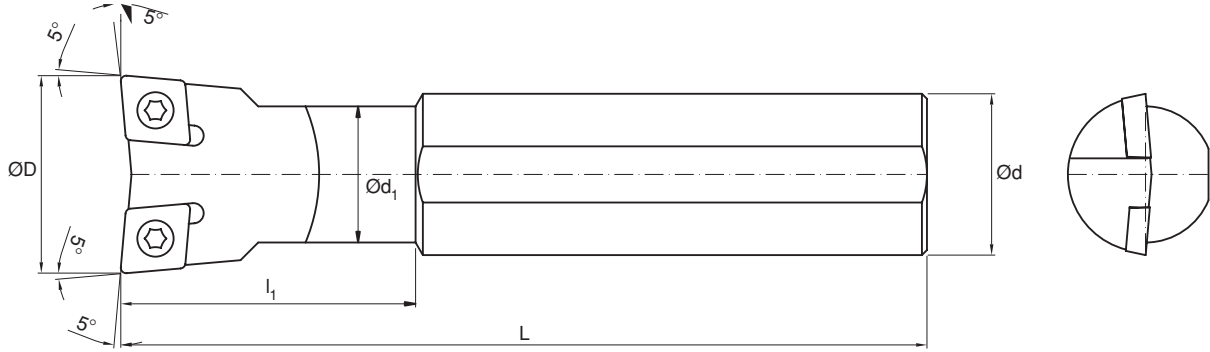

Ordering No. Takım Kod No.	Stock Stok	DIMENSION KATER ÖLÇÜLERİ						Insert Kesici Uç	Screw Sıkma Vidası	Insert Kesici Uç	Screw Sıkma Vidası	Wrench Torx Anahtar
		ØD	Ød ₁	Ød	l ₁	L	ØDmax					
S 16 Q SCR - SCL 06 - 06	○	16	13	20	40	180	24	CCM..0602	7815101	CCM..0602	7815101	T08
S 22 R SCR - SCL 09 - 09	○	22	17.5	25	50	200	29	CCM..09T3	7883209	CCM..09T3	7883209	T15
S 25 S SCR - SCL 09 - 09	○	25	20.5	32	70	250	36					
S 28 S SCR - SCL 09 - 12	○	28	23.5	32	70	250	36	CCM..09T3	7883209	CCM..1204	7883202	T15
S 36 T SCR - SCL 12 - 12	○	36	29.5	32	85	300	37	CCM..1204	7883202	CCM..1204	7883202	T15

Processing Flow / İşleme Şekli

